

Main Features:



- Input Voltage: 180~528Vac or 250~740Vdc
- Output Wattage: **800W** with C.C. or Adjustable Current Setting
- Programmable Method: Wire (Analog) or Wireless (NFC)
- Dimming Output Signal: **0-10V with Dim to off (dto)**
- Lightning Protection: Built-in [Line to line 6kV, line to ground 10kV]
- Reliability Protection: OVP, SCP, OTP
- Safety Regulation: Complies with UL8750 & EN61347
- **Type TL and HL** Program Certified from UL
- **Class P** UL standard for retrofit kit
- Waterproof Rating: IP67
- Seven Year Warranty under Normal Usage Conditions



SPECIFICATION

Model No. (*)	Output Voltage Range	C.C. or C.P. Programmable Rated Output or Range	Programming Method	Dimming Control Method	Dim to off (dto)	Aux
	(Vdc)	(mA) (i)			(V or %)	(Vdc)
LDD-800-040-20K-HH	24 - 40	20000	n/a	n/a	n/a	n/a
LDD-800-040-20K-HH-D	24 - 40	20000	n/a	DALI	0 (±6.5)	n/a
LDD-800D40-20K-HH-V	24 - 40	20000	n/a	0-10V	0.5V or 5%	12
LDD-800-053-15K-HH	31 - 52	15000	n/a	n/a	n/a	n/a
LDD-800-053-15K-HH-D	31 - 52	15000	n/a	DALI	0 (±6.5)	n/a
LDD-800D053-15K-HH-V	31 - 52	15000	n/a	0-10V	0.5V or 5%	12
LDD-800-093-8600HH	55 - 93	8600	n/a	n/a	n/a	n/a
LDD-800-093-8600HH-D	55 - 93	8600	n/a	DALI	0 (±6.5)	n/a
LDD-800D093-8600HH-V	55 - 93	8600	n/a	0-10V	0.5V or 5%	12
LDD-800-093F8600HH-V	55 - 133	6000 - 8600	Digital/NFC	0-10V	n/a	n/a
LDD-800-093P8600HH-V	55 - 133	6000 - 8600	Analog/Wire	0-10V	n/a	n/a
LDD-800D093F8600HH-V	55 - 133	6000 - 8600	Digital/NFC	0-10V/PWM	0.5V or 5%	12
LDD-800D093P8600HH-V	55 - 133	6000 - 8600	Analog/Wire	0-10V/PWM	0.5V or 5%	12
LDD-800-190-4200HH	114 - 190	4200	n/a	n/a	n/a	n/a
LDD-800-190-4200HH-D	114 - 190	4200	n/a	DALI	0 (±6.5)	n/a
LDD-800D190-4200HH-V	114 - 190	4200	n/a	0-10V	0.5V or 5%	12
LDD-800-190F4200HH-V	114 - 285	2800 - 4200	Digital/NFC	0-10V	n/a	n/a

LDD-800-190P4200HH-V	114 - 285	2800 - 4200	Analog/Wire	0-10V	n/a	n/a
LDD-800D190F4200HH-V	114 - 285	2800 - 4200	Digital/NFC	0-10V/PWM	0.5V or 5%	12
LDD-800D190P4200HH-V	114 - 285	2800 - 4200	Analog/Wire	0-10V/PWM	0.5V or 5%	12
LDD-800-286-2800HH	171 - 286	2800	n/a	n/a	n/a	n/a
LDD-800-286-2800HH-D	171 - 286	2800	n/a	DALI	0 (±6.5)	n/a
LDD-800D286-2800HH-V	171 - 286	2800	n/a	0-10V	0.5V or 5%	12
LDD-800-286F2800HH-V	171 - 381	2100 - 2800	Digital/NFC	0-10V	n/a	n/a
LDD-800-286P2800HH-V	171 - 381	2100 - 2800	Analog/Wire	0-10V	n/a	n/a
LDD-800D286F2800HH-V	171 - 381	2100 - 2800	Digital/NFC	0-10V/PWM	0.5V or 5%	12
LDD-800D286P2800HH-V	171 - 381	2100 - 2800	Analog/Wire	0-10V/PWM	0.5V or 5%	12
(*) model name pattern: LDD-<i>www</i>(D)<i>vvv</i>(P/F)<i>cccc</i>HH-(V/D) LDD means, LED Driver with C.C. (D) means, 12V Aux (P/F) means, Wire/Wireless Programming method (V/D) means, Analog Voltage/Digital DALI Dimming method		(i) Pre-set Constant Current Value with dimming Auxiliaries Voltage: 12V _{aux} with 300mA Dim to Off (dto) with 0.5W Standby Power Case Temp: T _c : 90C OVP: 110% V _o max, typ. OSP: 110% I _o max OTP: Lower the output current when T _c ≥ 105 ± 10°C; Auto Recovery When T _c ≤ 70 ± 10°C				

Input Spec.	Condition Description	Min.	Normal	Max.	Units
Input Voltage Range	Dedicated High Voltage Input	180	200-480	528	VAC
Input Frequency Range		47	50/60	63	Hz
Input Current	277 VAC/480 VAC input, full load output			3.5/2.0	A
Power Factor	@60% - 100% load		>0.9		
THD (total harmonic distortion)	@60% - 100% load		<15		%
Inrush Current	At 277 VAC input, 25°C cold start / At 480 VAC input, 25°C cold start			65 / 70	A
Leakage Current	max @277Vac 60Hz			1.0	mA
Surge Protection	Line to line 6kV, line to ground 10kV, IEC 61000-4-5		6K	10K	

Output Spec.	Condition Description	Min.	Normal	Max.	Units
Current Accuracy			±5		%
Ripple Current	At 100%-60% Load. The result differs according to different LED load characteristic.			< 5	% I _{p-p} (I _o)
Overshoot/Undershoot	% of I _{out} max & LED load			< 10	%
Turn-On Delay	Startup time at cold start			< 1.2	s
Auxiliary Power (V _{aux})	With 300mA max	-5%	12	+5%	Vdc

General Spec.	Condition Description	Min.	Normal	Max.	Units
Efficiency	Measured at full load in the thermal balanced condition		92	93	%
MTBF	measured at Tc= 75°C (MIL-HDBK-217F)		≥280,000		Hours
Lifetime	measured at Tc= 75°C		≥100,000		Hours
Case Temperature	marked in the Tc point of label		90		°C
Operating/Storage Temperature	10%RH~100%RH (See De-rating Curve for more details)	-40/-40		85/90	°C
Dimension (OL/L x W x H)	OL is the overall length with mounting plates	262/237*125*49			mm
		10.3/9.33*4.92*1.93			inch
Weight	Net weight without package	4.84/2.2			lb/kg
Packing	8pcs/Carton/20.5kg, 490x370x250mm				

Safety & EMC Compliance	Category	Condition Description
Safety Regulations	UL8750	Light Emitting Diode(LED) Equipment for Use in Lighting Products
	UL1012	Power Unit Other Than Class 2
	IEC 61347-1	Lamp Control gear Part 1: General and Safety Requirements
	IEC 61347-2-13	Lamp Control gear Part 2-13: Particular Requirement for d.c. or a.c. Supplied Electronic Control gear for LED Modules
	CE	Europe: EN 61347-1, EN61347-2-13
EMI Standards	IEC 55015	Conducted emission test & Radiated emission test
	IEC 61000-3-2	Harmonic current emissions; Class C
	IEC 61000-3-3	Voltage fluctuations & flicker
	FCC Part 15	ANSI C63.4:2009 Class B
EMS Standards	IEC 61000-4-2	Electrostatic discharge (ESD): 8 kV air discharge, 4 kV contact discharge
	IEC 61000-4-3	Radio frequency electromagnetic field susceptibility test (RS)
	IEC 61000-4-4	Electrical fast transient (EFT)
	IEC 61000-4-5	Surge immunity test
	IEC 61000-4-6	Conducted radio frequency disturbances test (CS)
	IEC 61000-4-8	Power frequency magnetic field test
	IEC 61000-4-11	Voltage dips
	IEC 61547	Electromagnetic immunity requirements applies to lighting equipment

■ Dimming Curve

Parameter	Min.	Typ.	Max.
Vdim Sourcing Current	200uA	300uA	450uA
Vdim Allowed Input Voltage	-20 V		20 V
0-10V Dimming Range	10% (Vdim=1V)	Linear	100% (Vdim=9~10V)
PWM Dimming Range	10% (Duty=10%)	Linear	100% (Duty=90-100%)
Dim off threshold		0.5V or 5%	0.6V or 6%
Dim on threshold	0.6V or 6%	0.7V or 7%	
PWM High	3V		10V
PWM Low	0V		0.6V
PWM Frequency	300Hz		2kHz
External PWM Controller Current Sinking Capability	300uA		
DALI Interface Standard		IEC62386	
DA1,DA2 High Level	9.5	16	22.5
DA1,DA2 Low Level	-6.5	0	6.5
DA1,DA2 Current	0		2mA

Dimming Wire

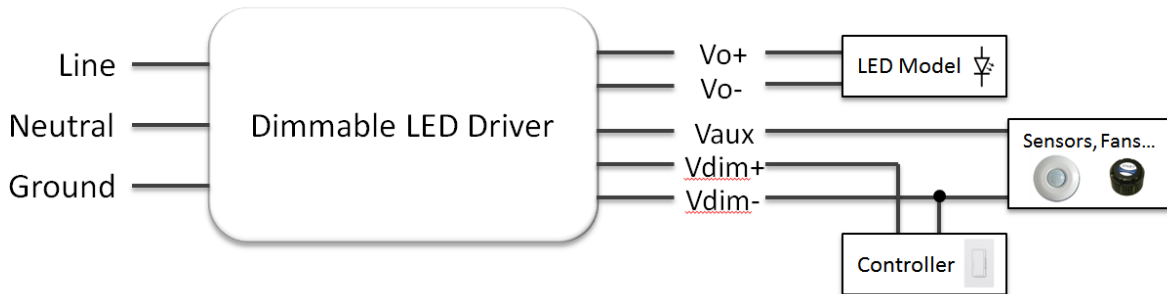

With dim-off (dto)

0-10V Dimming Curve

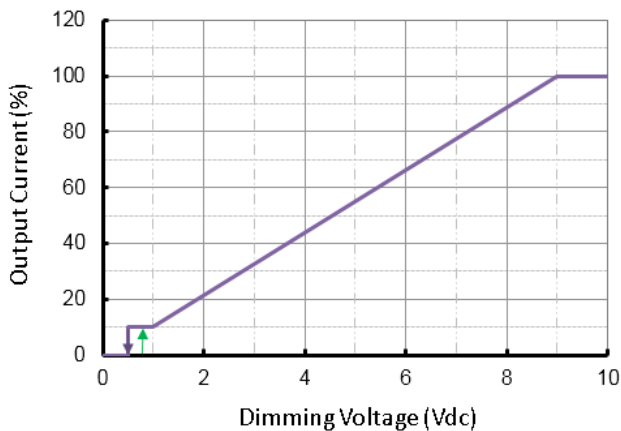

PWM Dimming Curve

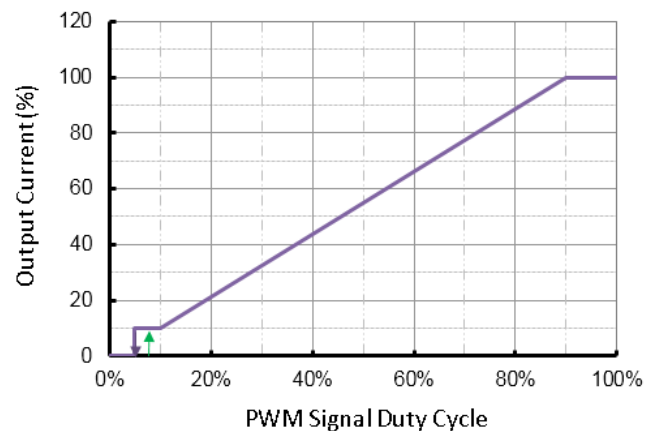

■ Lifetime vs. Case Temperature

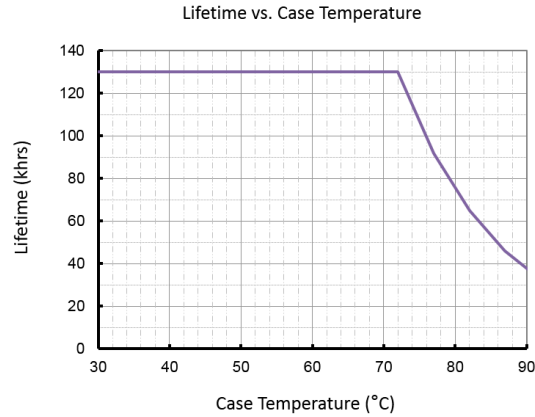

(End of Life: Maximum Failure Rate=10%)

■ THD vs. Load

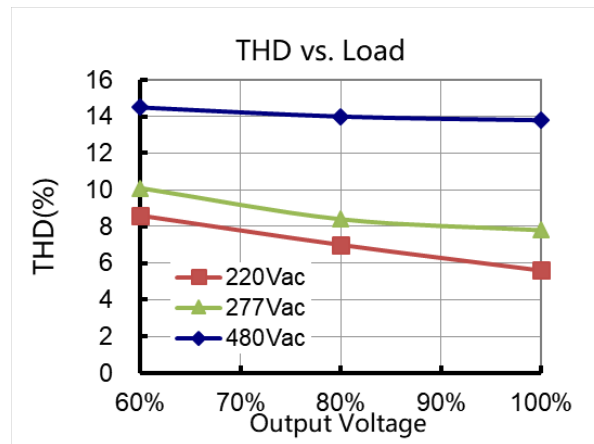

■ Efficiency vs. Load

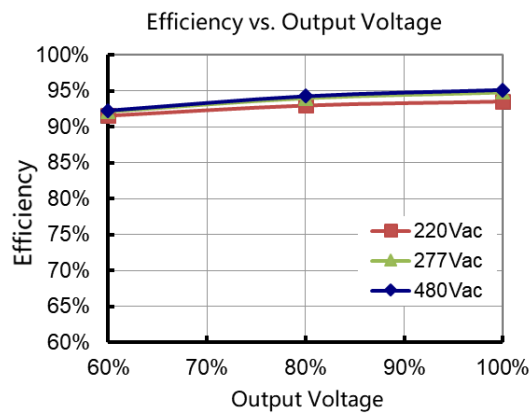

■ Current vs. Voltage Curve

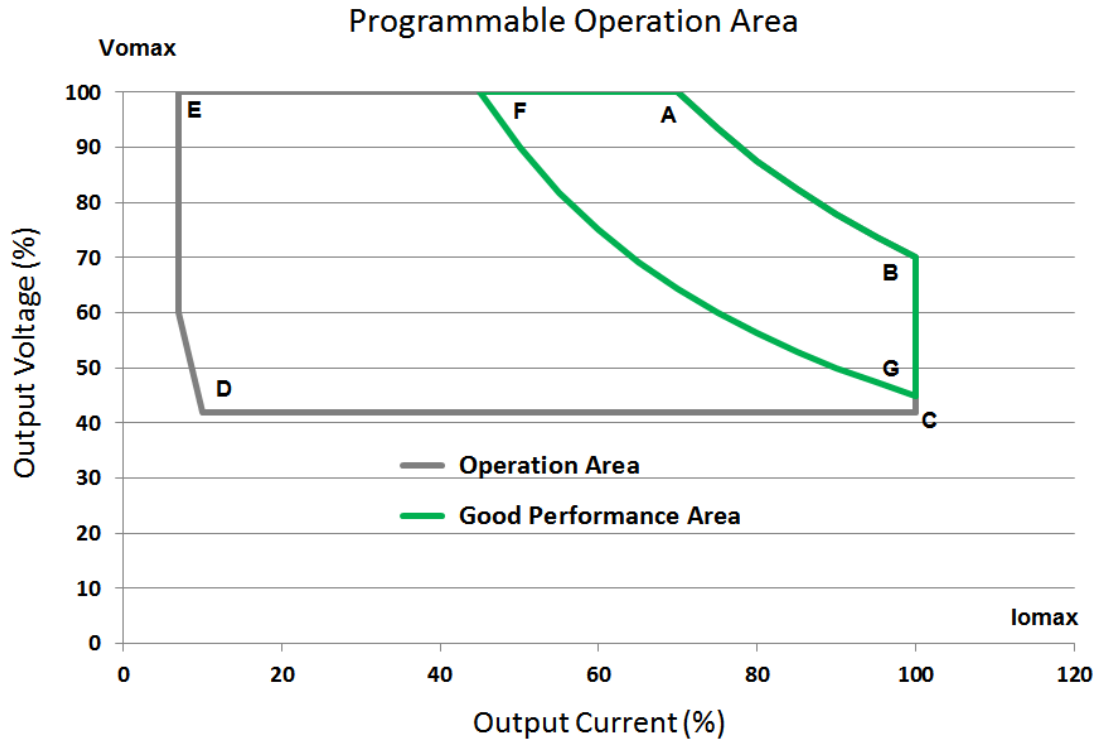

LDD-6-VVVxCCCC-HH-V, while x = F for NFC and x = P for Wire

I_o (mA) V_o (V)	B I_{max} (Rated Current)	A V_{max}	F (60% of I at A) (as V_{max})	G (as I_{max}) (60% of V at B)	C (as I_{max}) $V_{min} =$ (60% of V at B)	D (10% of I_{max}) (60% of V at B)	E (10% of I at A) (as V_{max})
LDD-800-093x8600HH-V	8600 93	6000 133	3600 133	8600 56	8600 56	860 56	600 133
LDD-800D093x8600HH-V	8600 93	6000 133	3600 133	8600 56	8600 56	860 56	600 133
LDD-800-190x4200HH-V	4200 190	2800 286	1680 286	1680 86	1680 86	420 86	280 286
LDD-800D190x4200HH-V	4200 190	2800 286	1680 286	1680 86	1680 86	420 86	280 286
LDD-800-286x2800HH-V	2800 286	2100 381	1260 381	2800 172	2800 172	280 172	210 381
LDD-800D286x2800HH-V	2800 286	2100 381	1260 381	2800 172	2800 172	280 172	210 381
On BA Curve Line	Constant Power Area						
Within BAFG Box	Good Performance Area						
Within ABCDE Box	Operational Area						

■ Mechanical Outline (Unit: mm)

Note: Dimensions in millimeters, where 25.4 mm = 1 inch

Tolerance: ± 0.51 mm

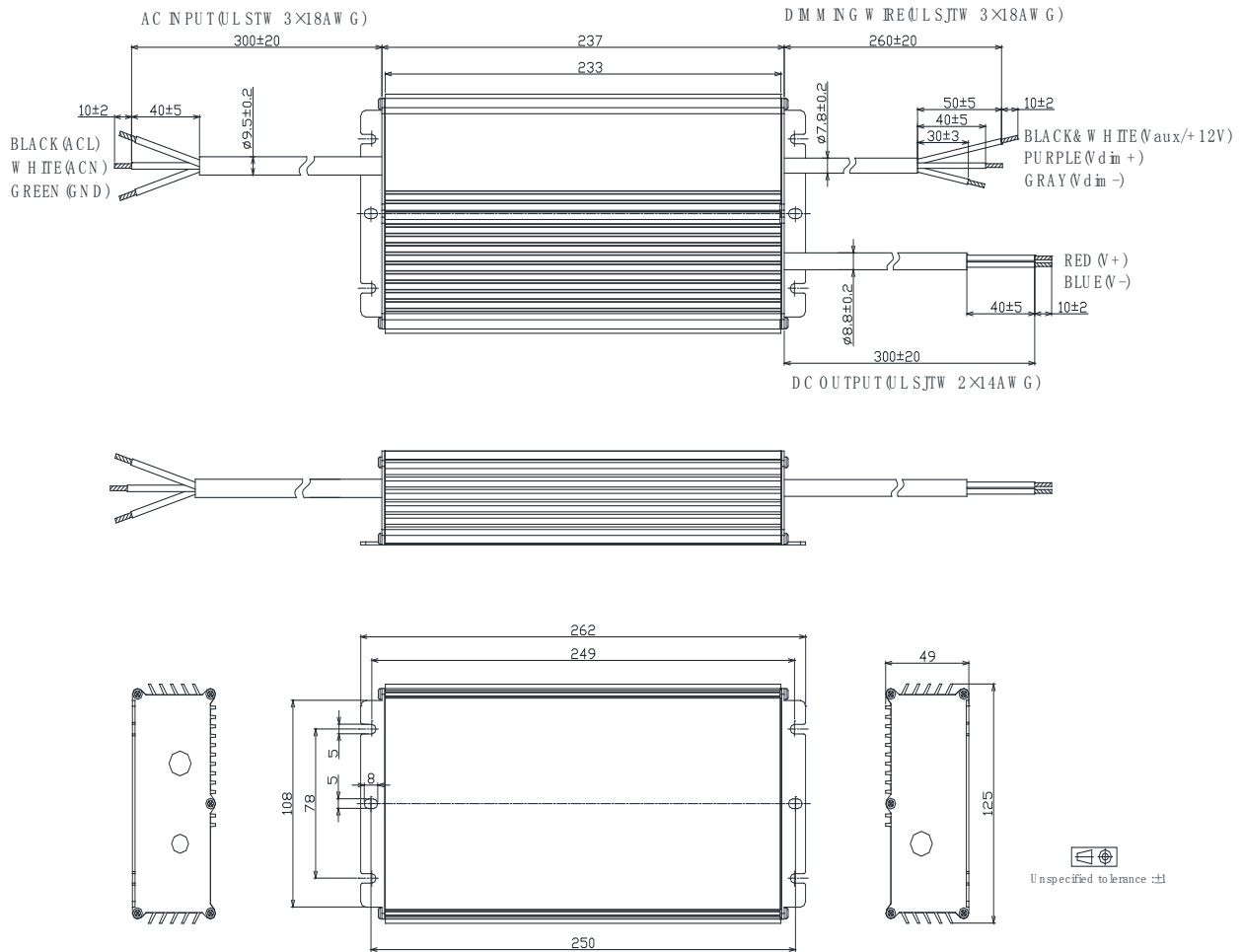

Figure 45, ARYPT

Safety Note: Please make sure the output cable does not connect to dimming cable or the cables of other drivers until 20 seconds after being tested because of the remained voltage in the output capacitor.

Revision

Date	Rev.	Description of Change		
		Item	Old	New
8/5/2020	V2a	In Draft Release	/	/
8/10/2020	V2b	Change model name	“cccc-HH”	“cccHH”
		Add new model series (non-programmable)		LDD-800-040-20K-HH series LDD-800-052-15K-HH series
8/13/2020	V2c	Update dedicated High Voltage Input	250-528Vac	180-528Vac
		Modify models	LDD-800-080-10K-HH	LDD-600-093-8600HH series
		Add Dimming spec for DALI		DALI Interface Standard IEC62386
10/22/2020	V2d	forward voltage range	LDD-800-093-8600HH 55-133 LDD-800-190-4200HH 114-285 LDD-800-286-2800HH 171-381	LDD-800-093-8600HH 55 – 93 LDD-800-190-4200HH 114-190 LDD-800-286-2800HH 171-286