

CM 0.77 GIVX

The lens arrays of Fresnel Technologies' CM 0.77 GIVX series are intended to be used in ceiling-mounted passive infrared motion detector devices. They are used with the grooved side facing the pyroelectric detector, and their mounting flange is intended to be 0.46" (11.7 mm) from the detector's sensitive area, and centered about it (see Figure 1).

The overall dimensions of the arrays are 2.066" \pm 0.010" (52.5 mm \pm 0.3 mm) in diameter by 0.310" \pm 0.010" (7.9 mm \pm 0.3 mm) deep by 0.020" \pm 0.004" (0.5 mm \pm 0.1 mm) thick. The mounting flange is approximately 0.3" (7.8 mm) wide. Centering is held to 0.005" (0.12 mm).

Fresnel Technologies, Inc. is the premier manufacturer of Fresnel lens arrays. We have led the industry in the development of new lenses and materials to advance the state of the art of passive infrared motion detection. Our lenses and lens arrays have been incorporated into most passive infrared devices using refractive optics since 1976. Our quality standards are the highest in the industry. Surface finish and inclusions are such that no defect is visible at a distance of 3 feet (1 meter) under ordinary light. There are no functional flaws in our products whatsoever. Our POLY IR® infrared-transmitting materials are the best available in stiffness and in transmittance in the 8 to 14 μ m region. Active lens segments are made from our acclaimed and proprietary LODIFF® lens patterns.

We currently offer five types in this series: CM 0.77 GIV1, CM 0.77 GIV2, CM 0.77 GIV3, CM 0.77 GIV4 and CM 0.77 GIV5.

Figures 2-12 illustrate the zone patterns for the arrays. The figures postulate a dual-element detector with 110° coverage both up-down and left-right, amplifier gain of about 5,000, and a mounting height as shown in each figure. Other detector arrangements can be used, and the use of detectors with a higher degree of circular symmetry, including four-element detectors with a square pattern, is encouraged. Assistance with zone patterns for these detectors is available on request. If the detector you choose has a larger acceptance angle, the spacing between the detector and the flange can be reduced by as much as 3 mm without significantly degrading the performance of the central zones. This closer mounting will improve the outer zones and extend their range at the 8' (2.4 m) ceiling height.

CM 0.77 GIV1

CM 0.77 GIV2

CM 0.77 GIV3

CM 0.77 GIV4

CM 0.77 GIV5

NEW!

**fresnel
technologies inc.**

101 WEST MORNINGSIDE DRIVE
FORT WORTH, TEXAS 76110
(817) 926-7474
FAX: (817) 926-7146
www.fresneltech.com

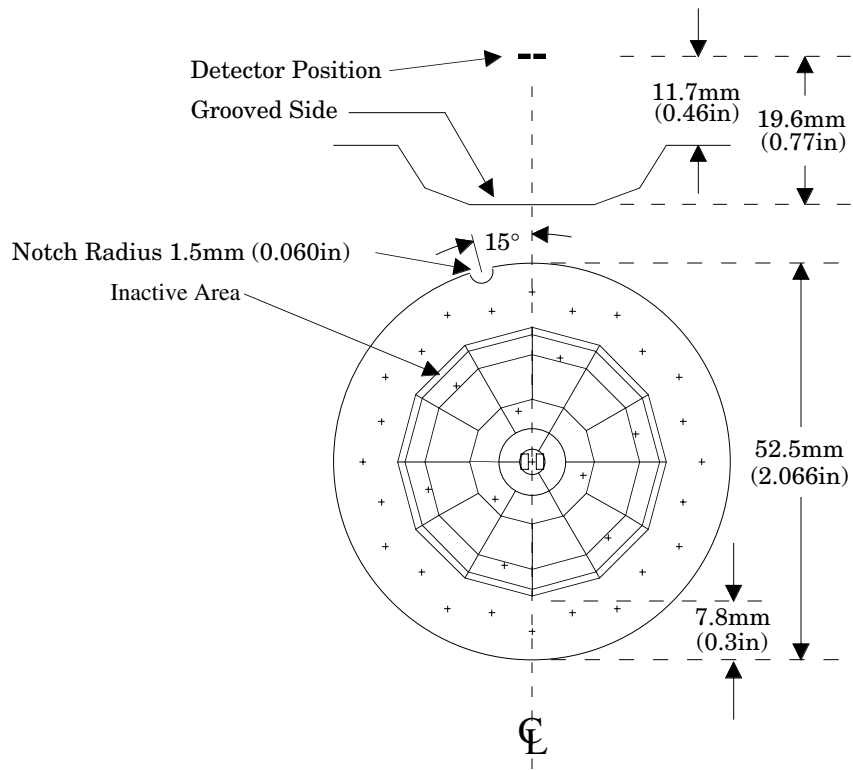

Details of mounting geometry

CEILING MOUNT ARRAY CM 0.77 GI V1

FRONT VIEW :

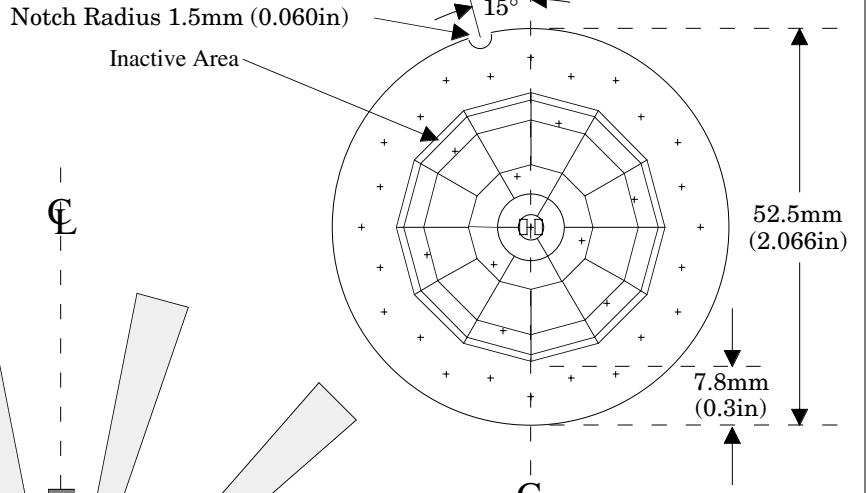
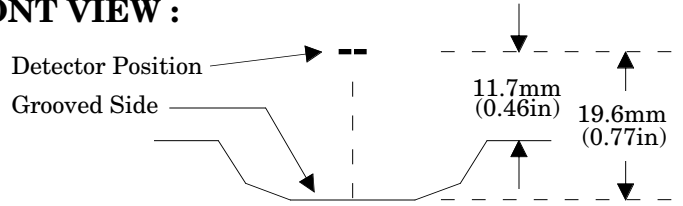

TOP VIEW:

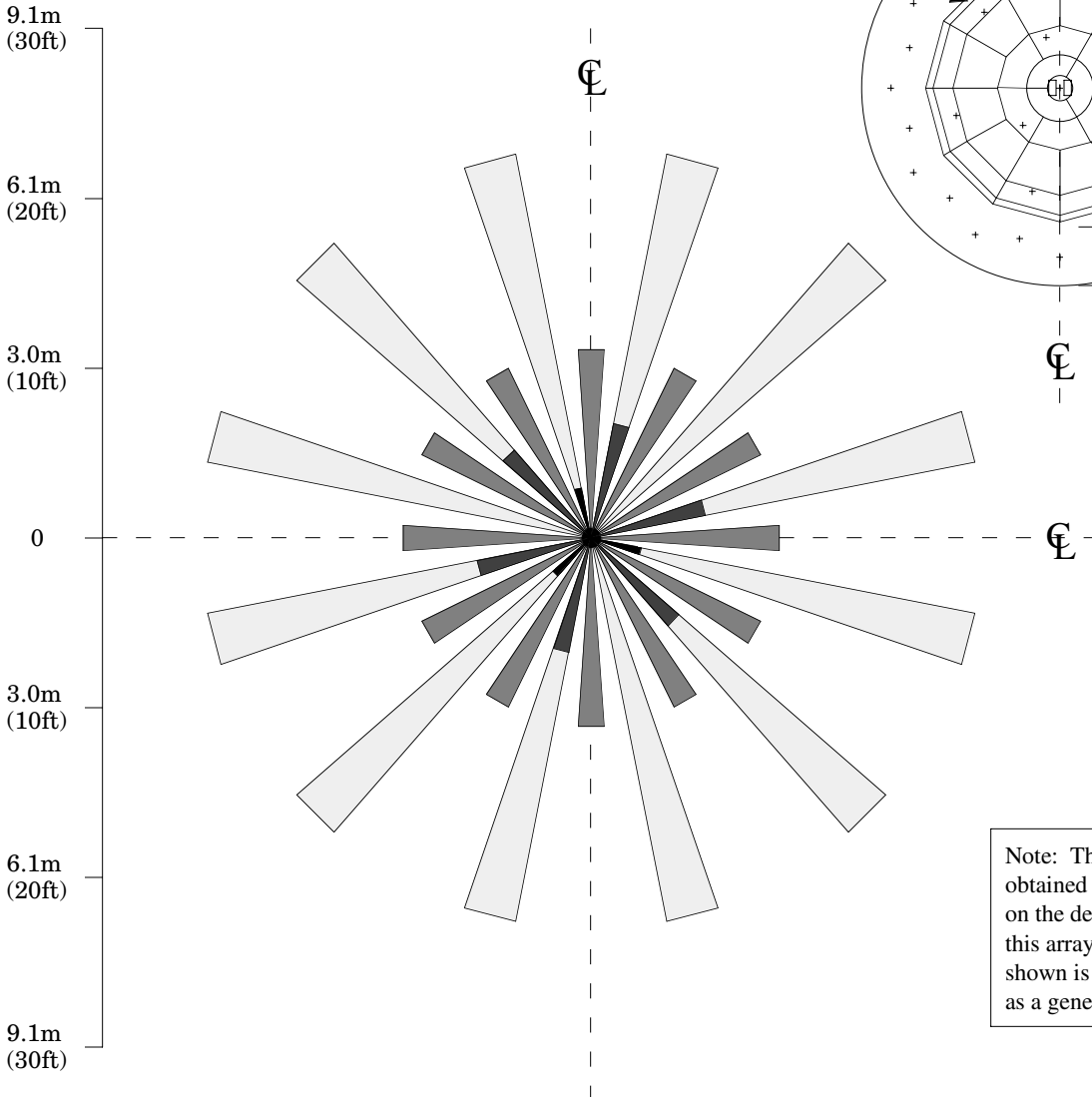

Note: The "beam" pattern obtained depends strongly on the detector used with this array. The pattern shown is intended solely as a general guide.

SIDE VIEW:

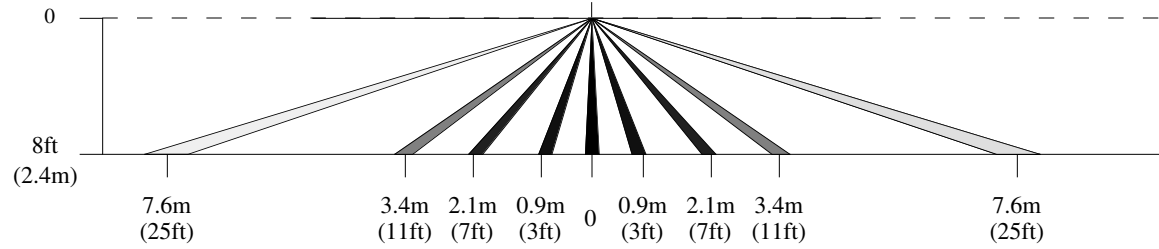
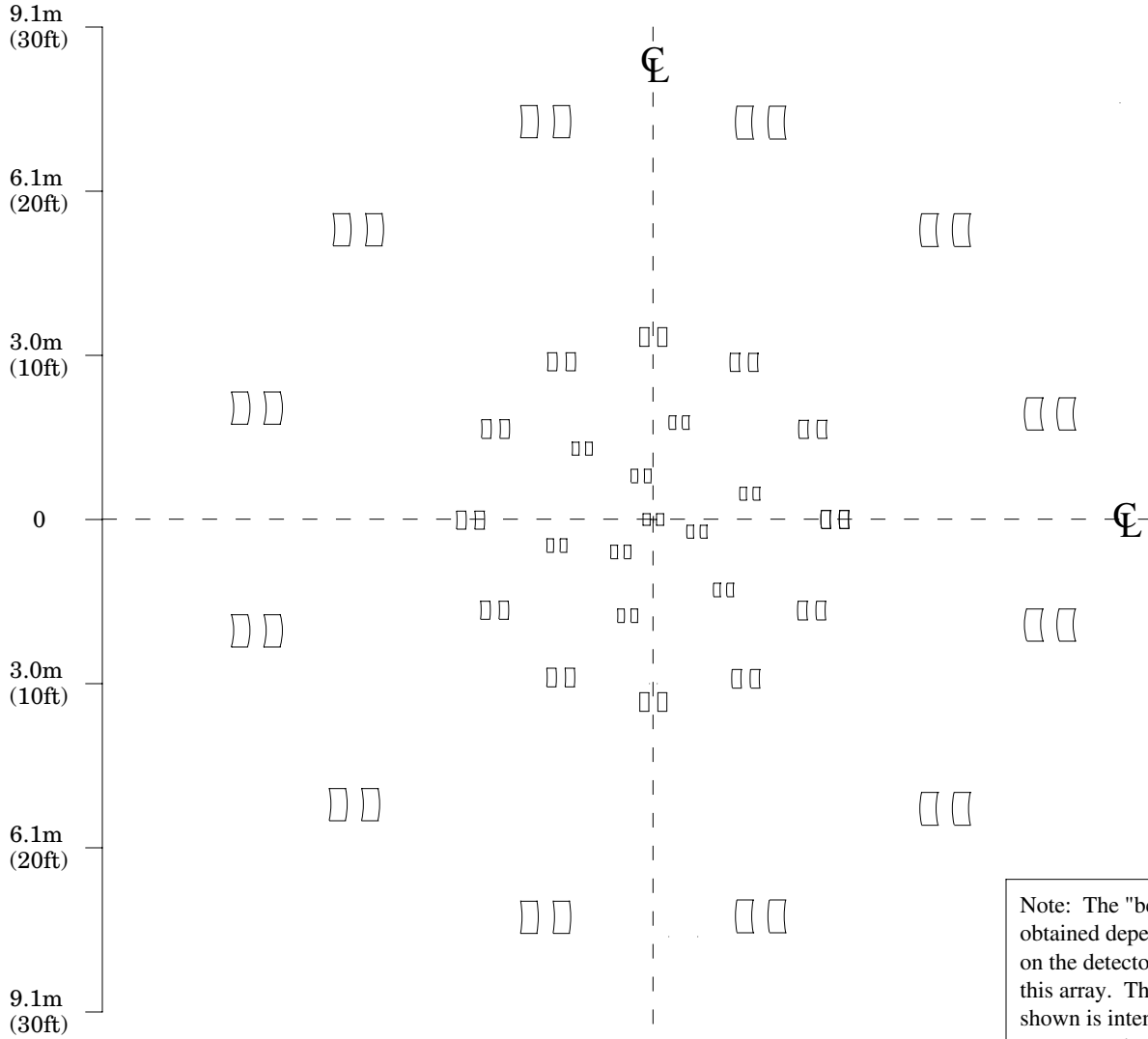

Figure 2

CEILING MOUNT ARRAY CM 0.77 GI V1

FLOOR COVERAGE:

(For mounting height of 2.4m (8ft))



Note: The "beam" pattern obtained depends strongly on the detector used with this array. The pattern shown is intended solely as a general guide.

SIDE VIEW:

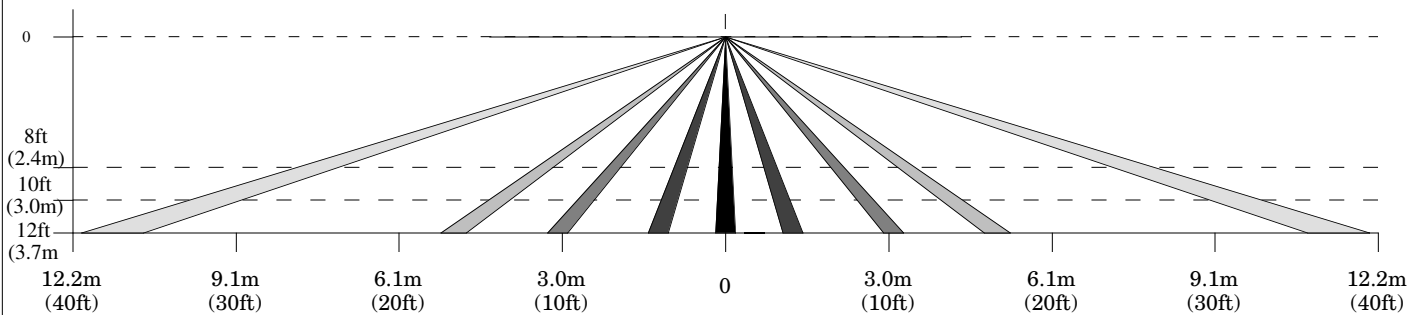
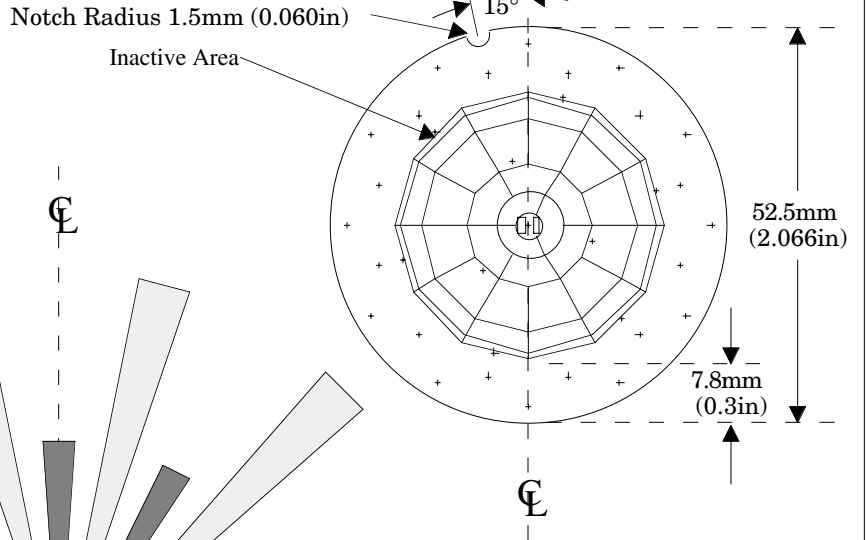
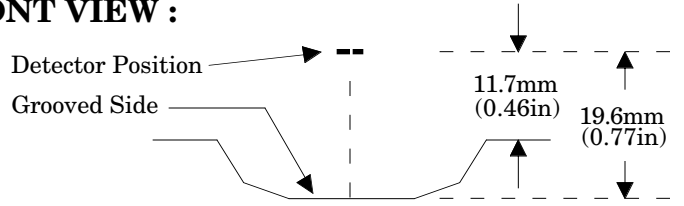

Figure 3

CEILING MOUNT ARRAY CM 0.77 GI V2

FRONT VIEW :



TOP VIEW:

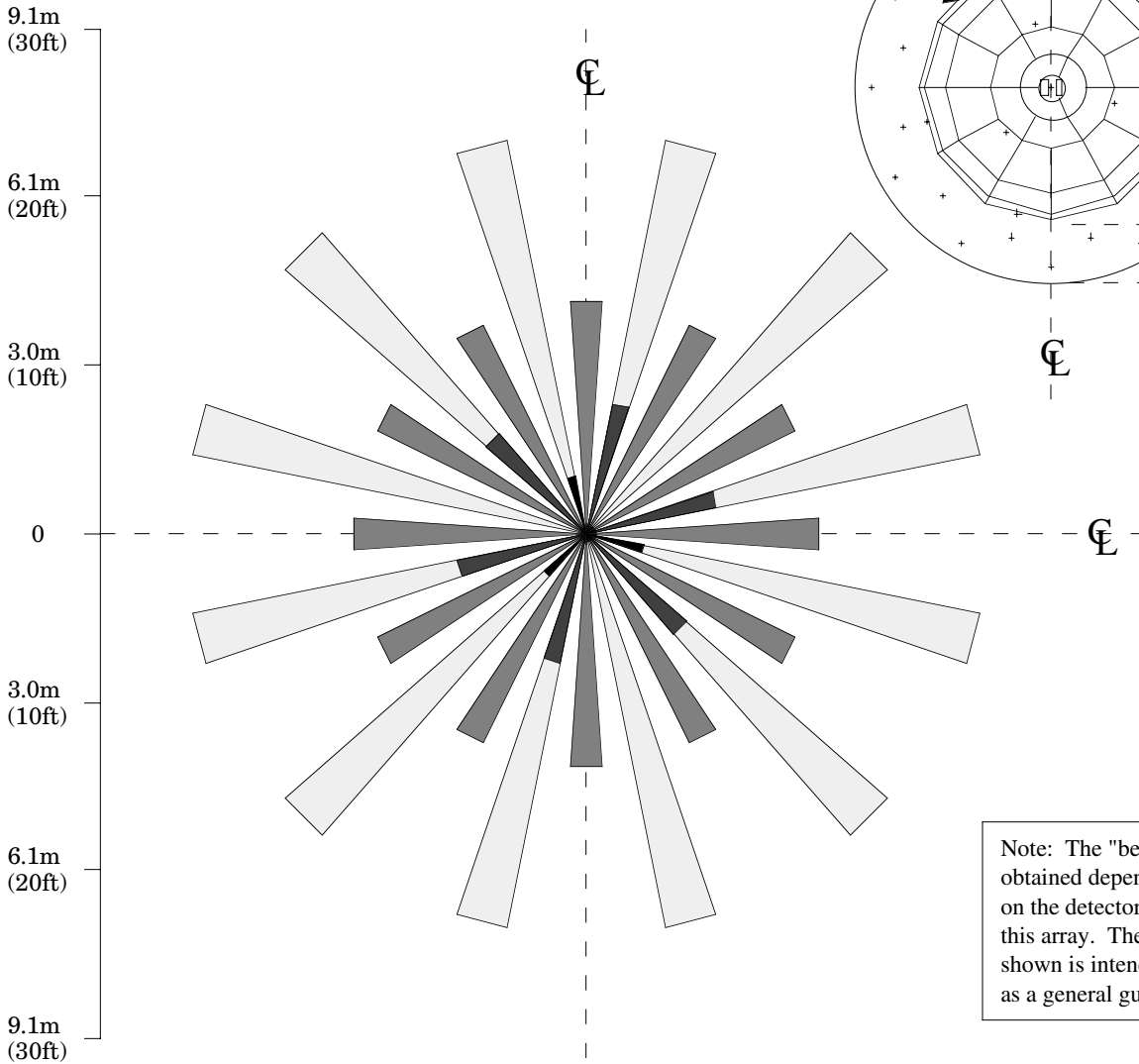

SIDE VIEW:

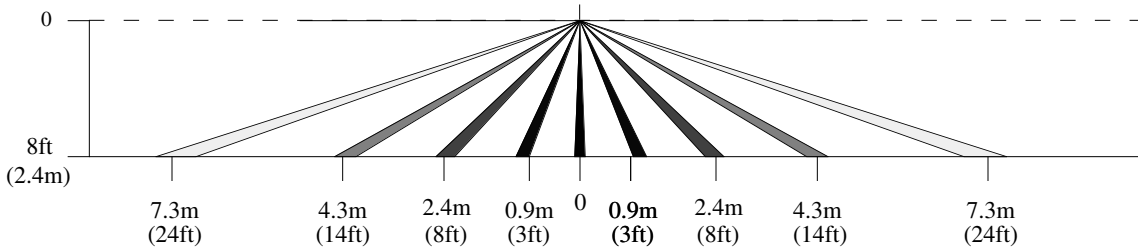

CEILING MOUNT ARRAY CM 0.77 GI V2

FLOOR COVERAGE:

(For mounting height of 2.4m (8ft))

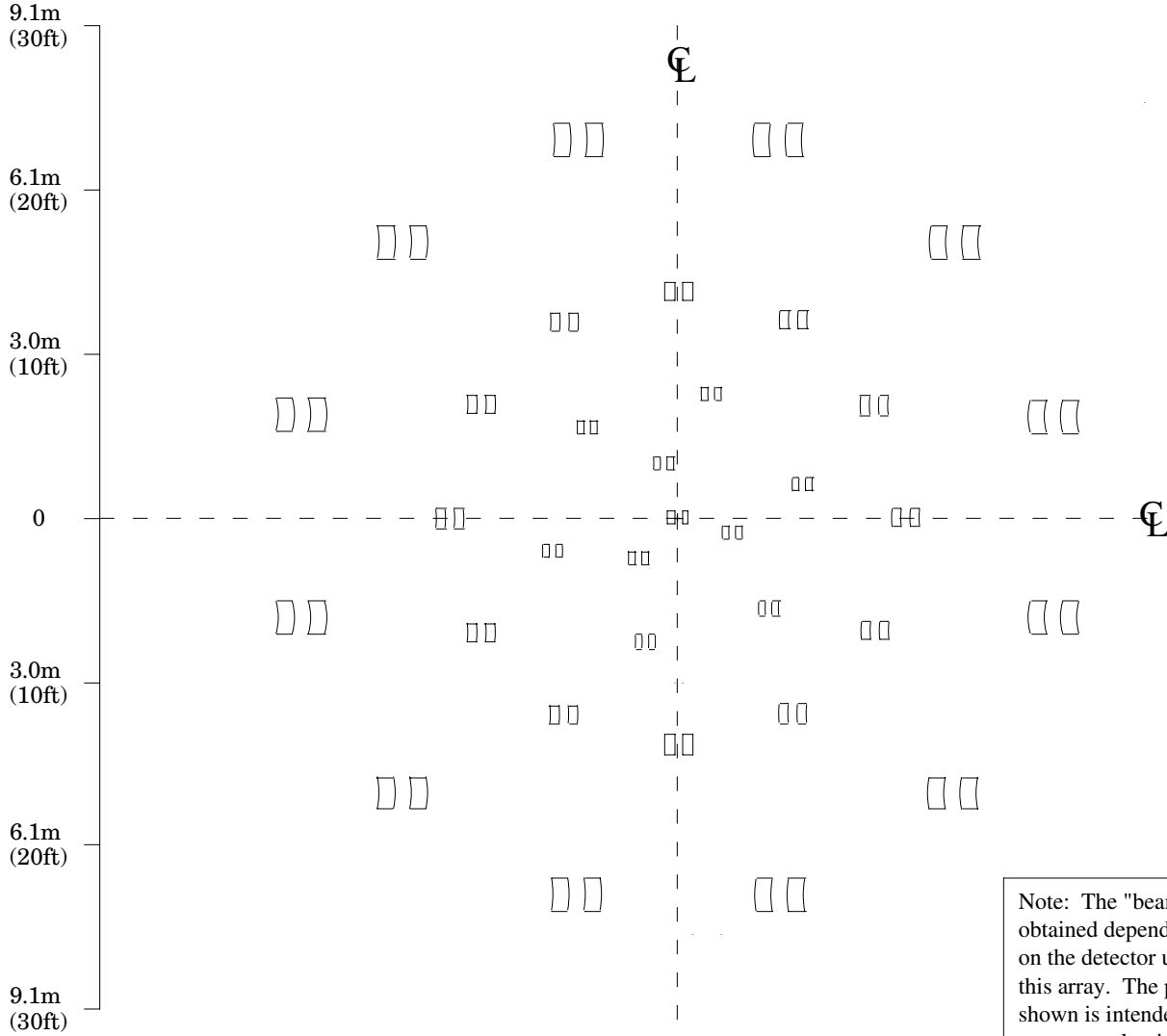

Note: The "beam" pattern obtained depends strongly on the detector used with this array. The pattern shown is intended solely as a general guide.

SIDE VIEW:

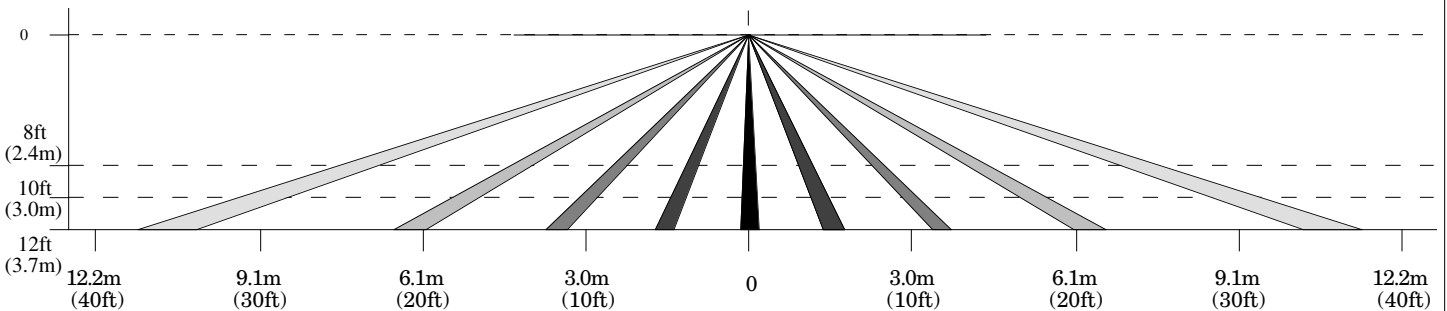
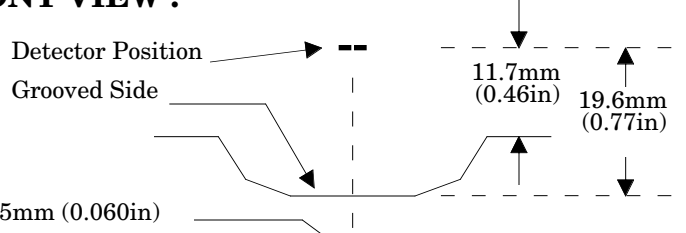

Figure 5

CEILING MOUNT ARRAY
CM 0.77 GI V3

FRONT VIEW :



TOP VIEW:

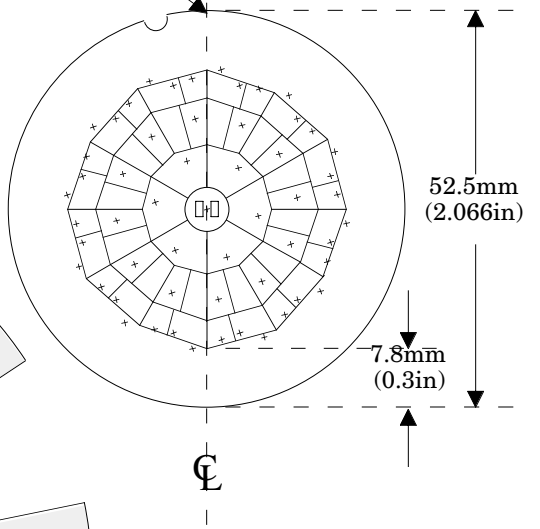
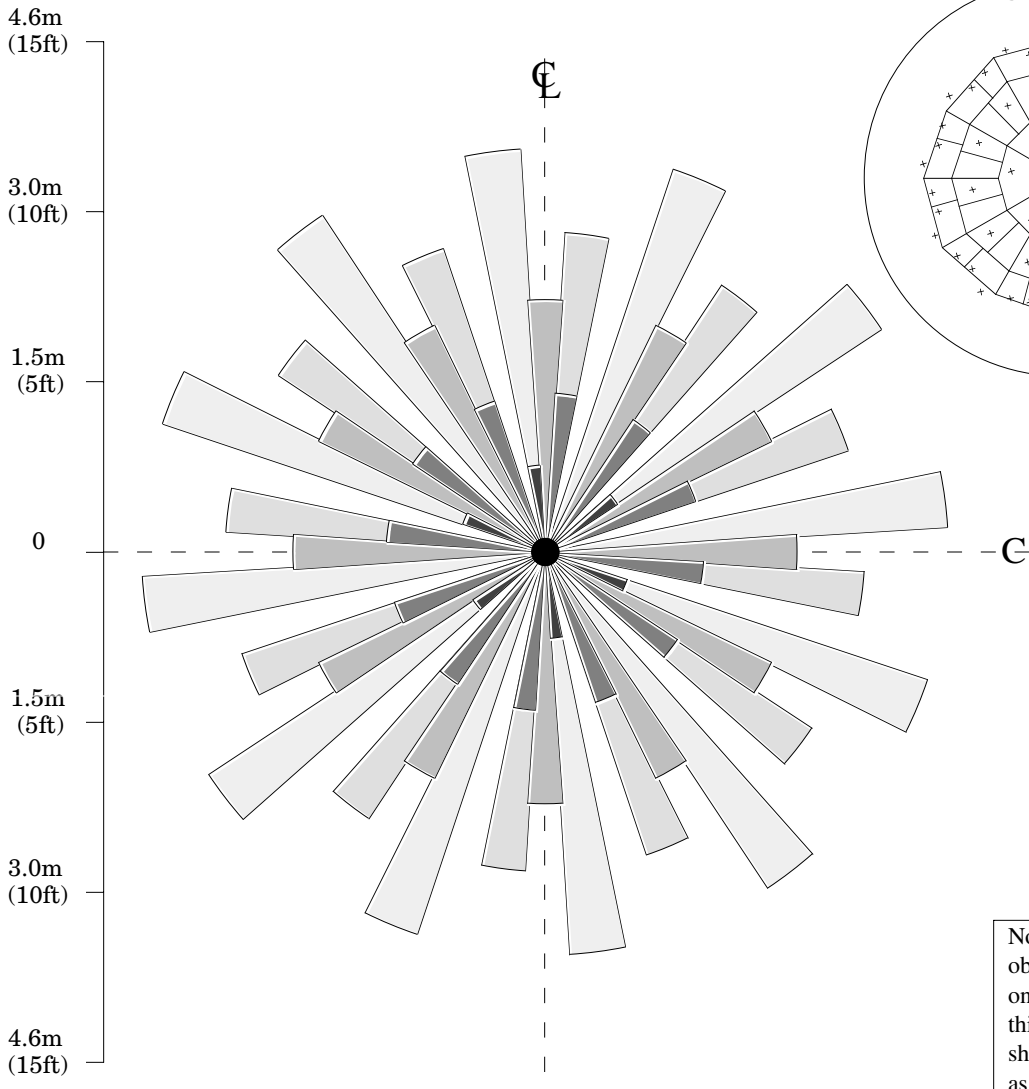

Note: The "beam" pattern obtained depends strongly on the detector used with this array. The pattern shown is intended solely as a general guide.

SIDE VIEW:

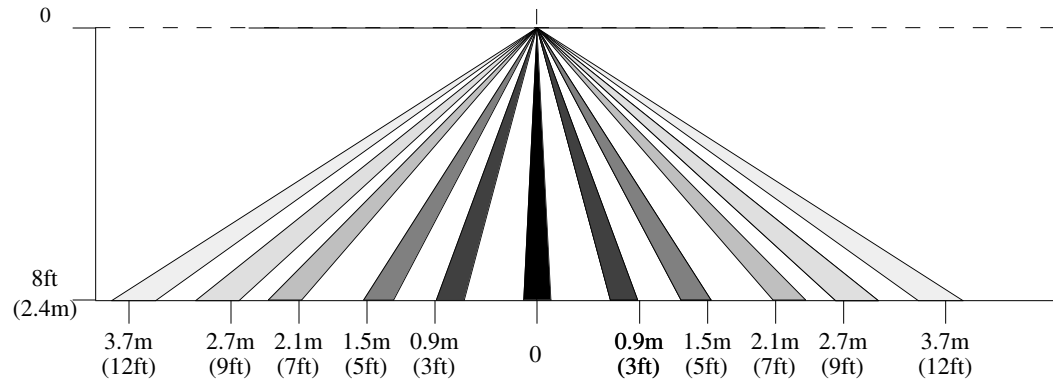

Figure 6

CEILING MOUNT ARRAY

CM 0.77 GI V3

FLOOR COVERAGE:

(For mounting height of 2.4m (8ft))

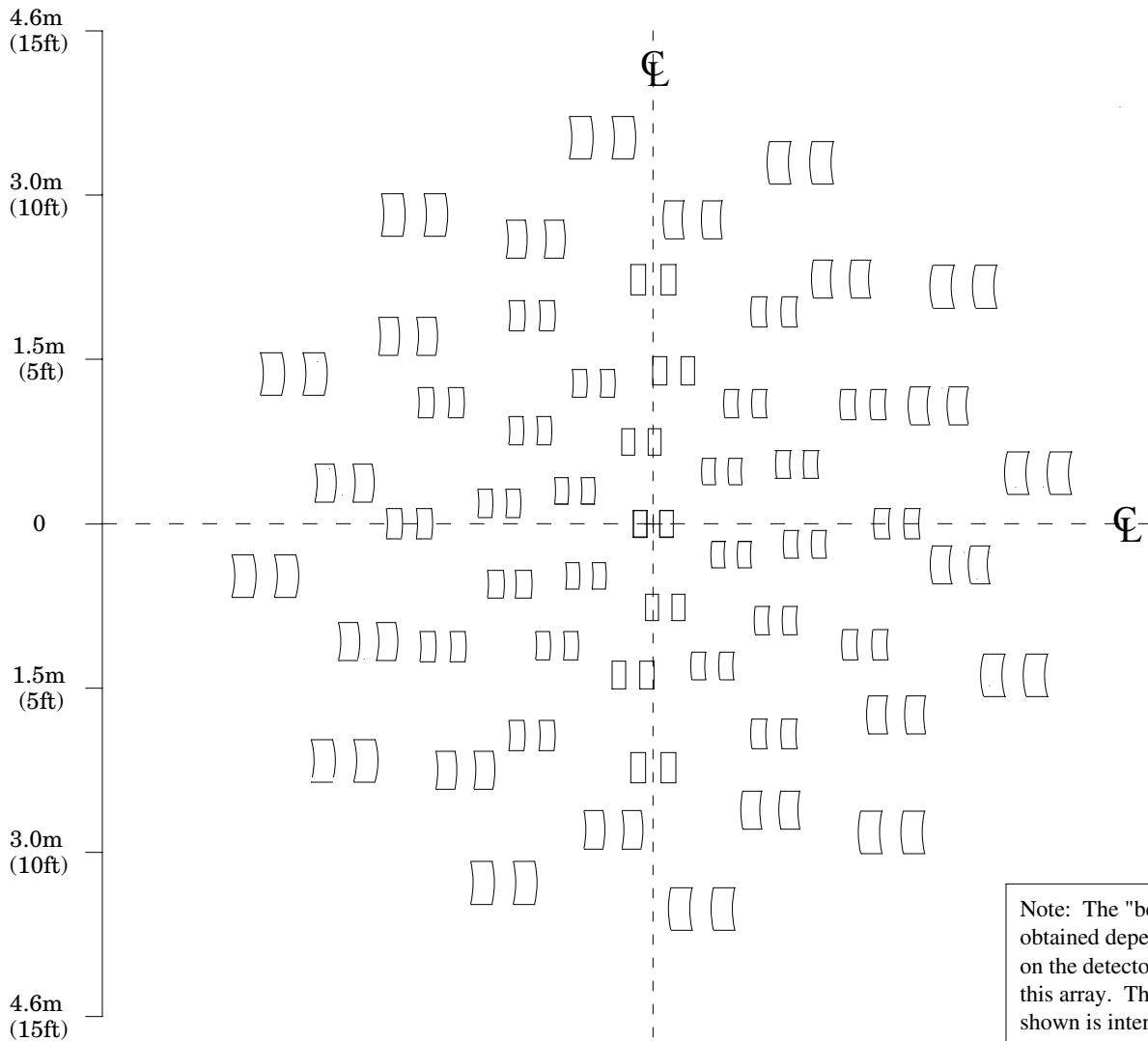

Note: The "beam" pattern obtained depends strongly on the detector used with this array. The pattern shown is intended solely as a general guide.

SIDE VIEW:

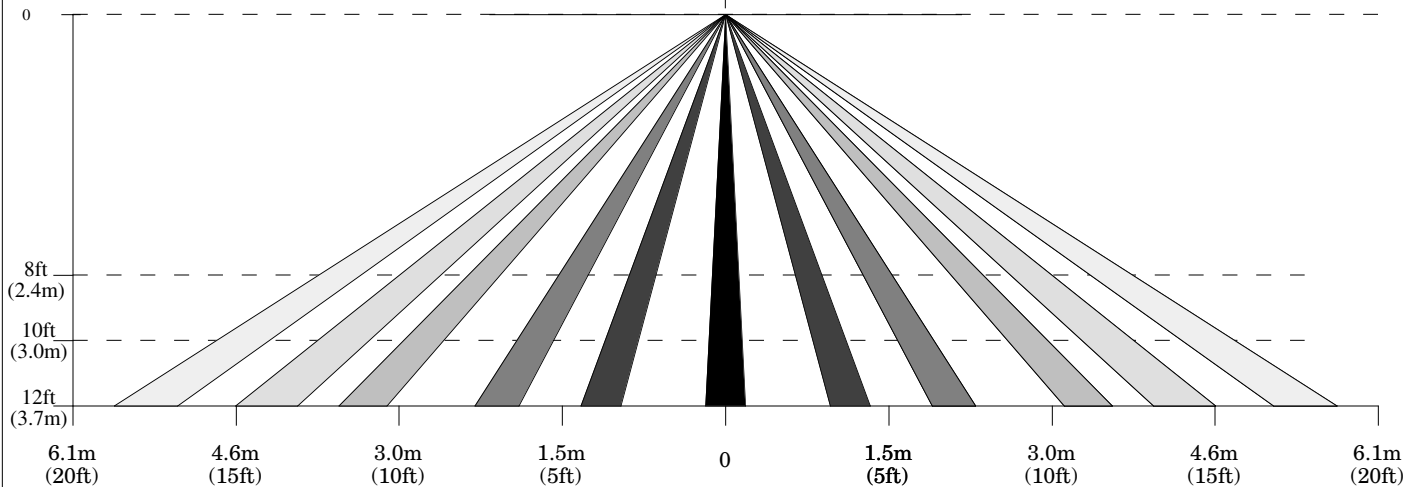
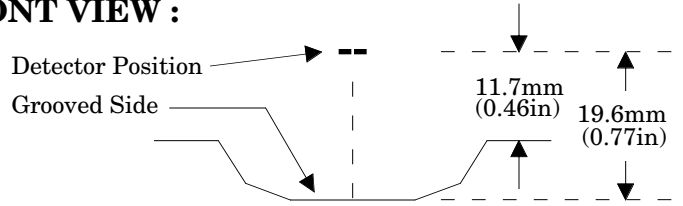

Figure 7

CEILING MOUNT ARRAY

CM 0.77 GI V4

FRONT VIEW :



TOP VIEW:

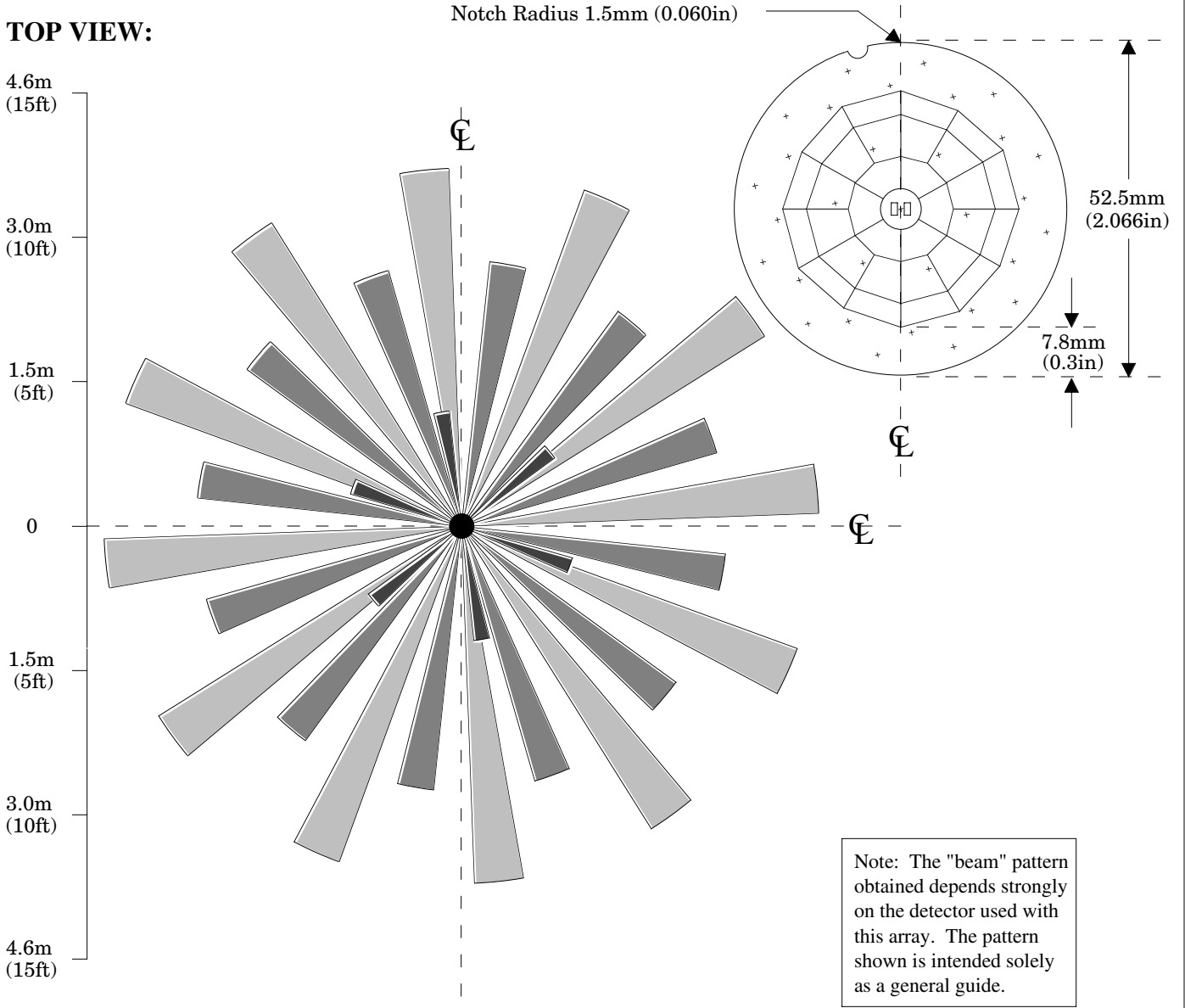

SIDE VIEW:



Figure 8

CEILING MOUNT ARRAY

CM 0.77 GI V4

FLOOR COVERAGE:

(For mounting height of 2.4m (8ft))

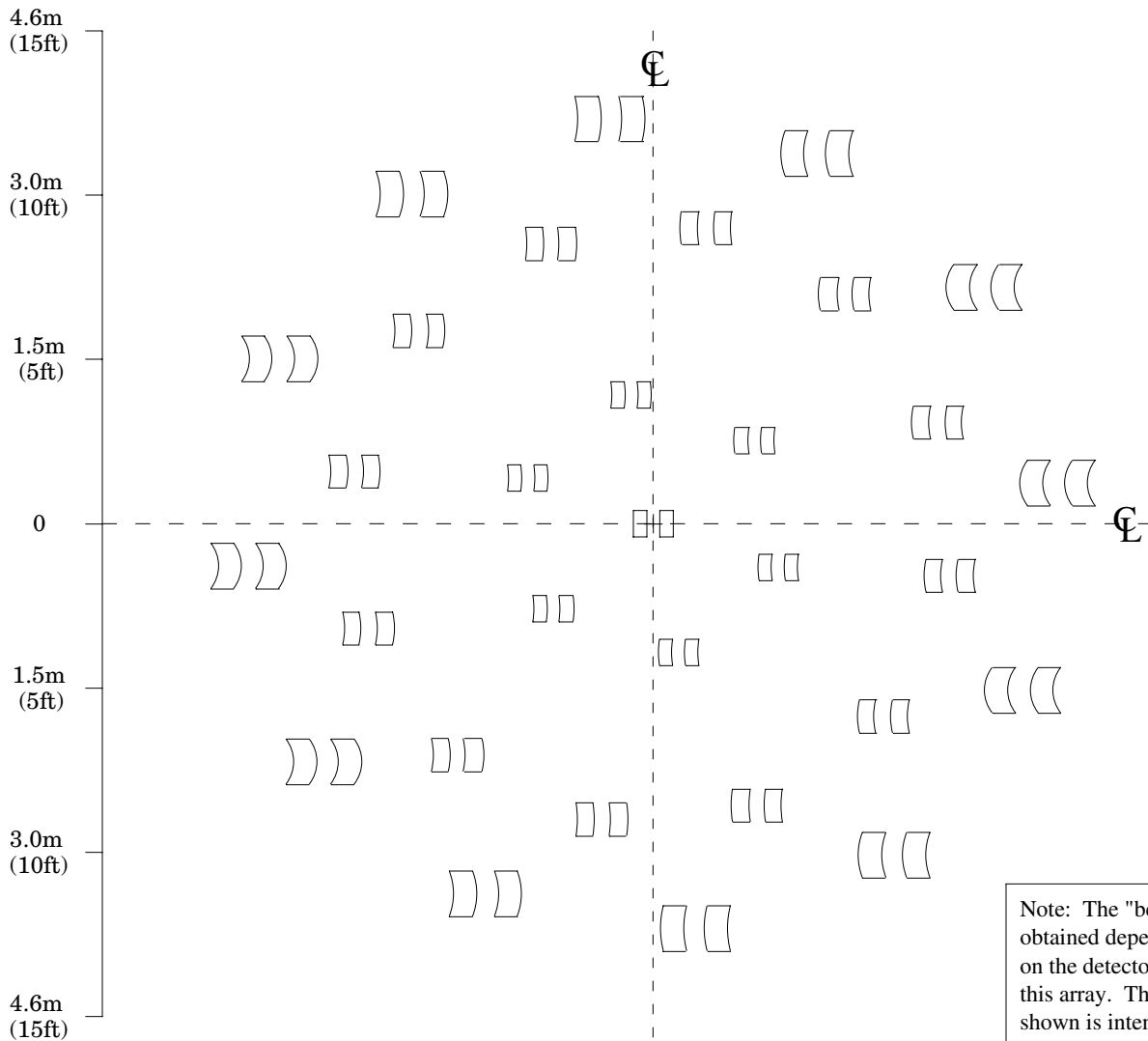

SIDE VIEW:

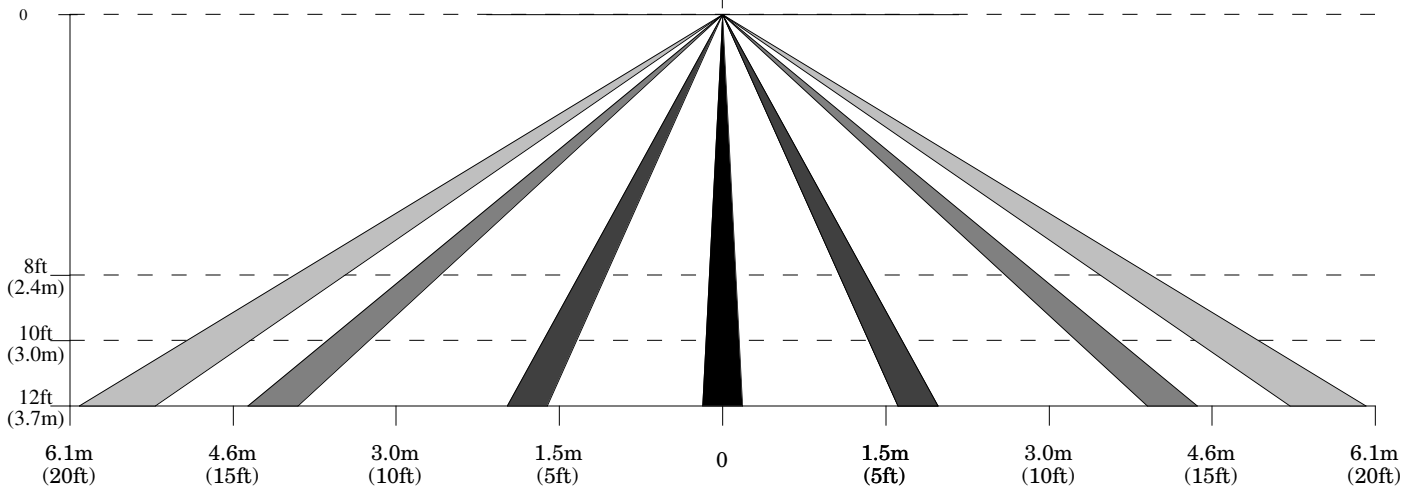
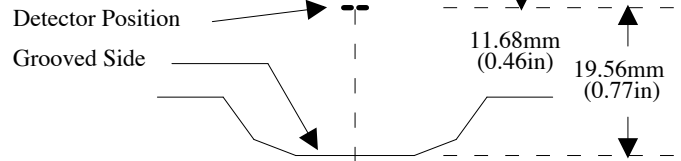

Figure 9

CEILING MOUNT ARRAY

CM 0.77 GI V5

FRONT VIEW :



TOP VIEW:

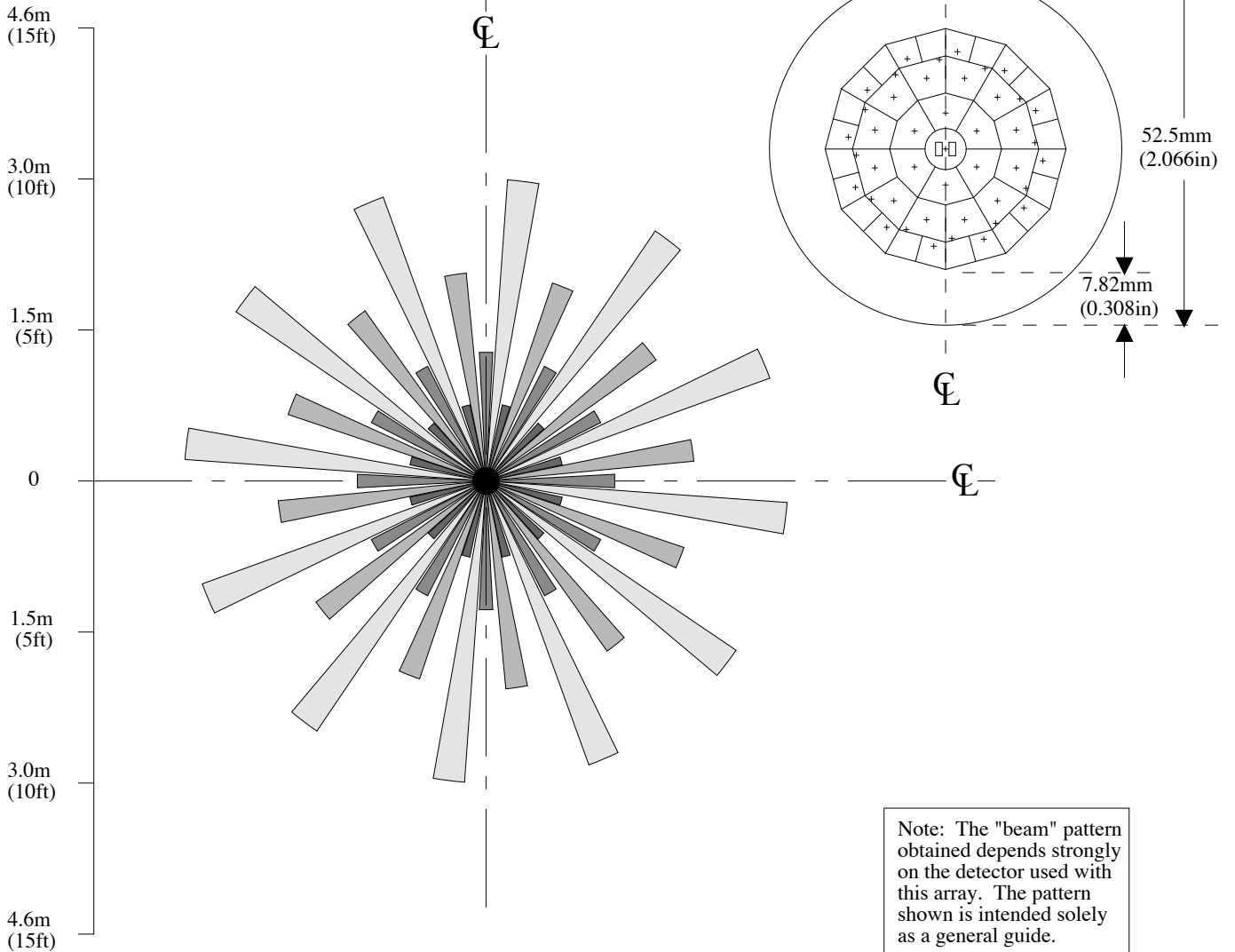

SIDE VIEW:

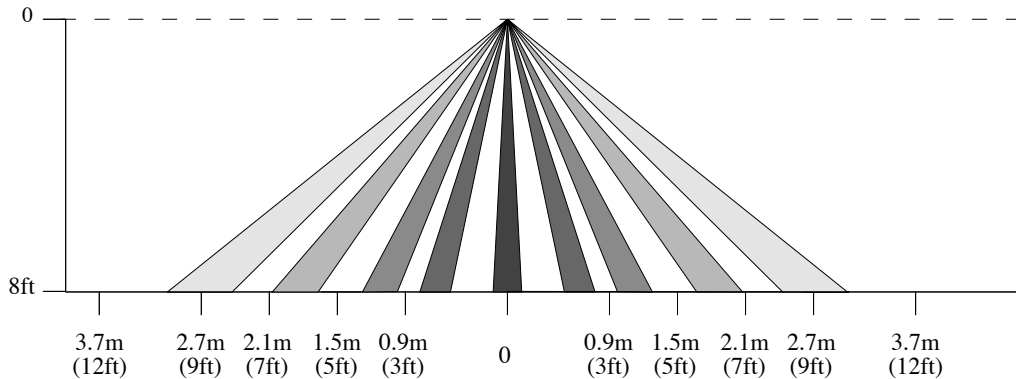
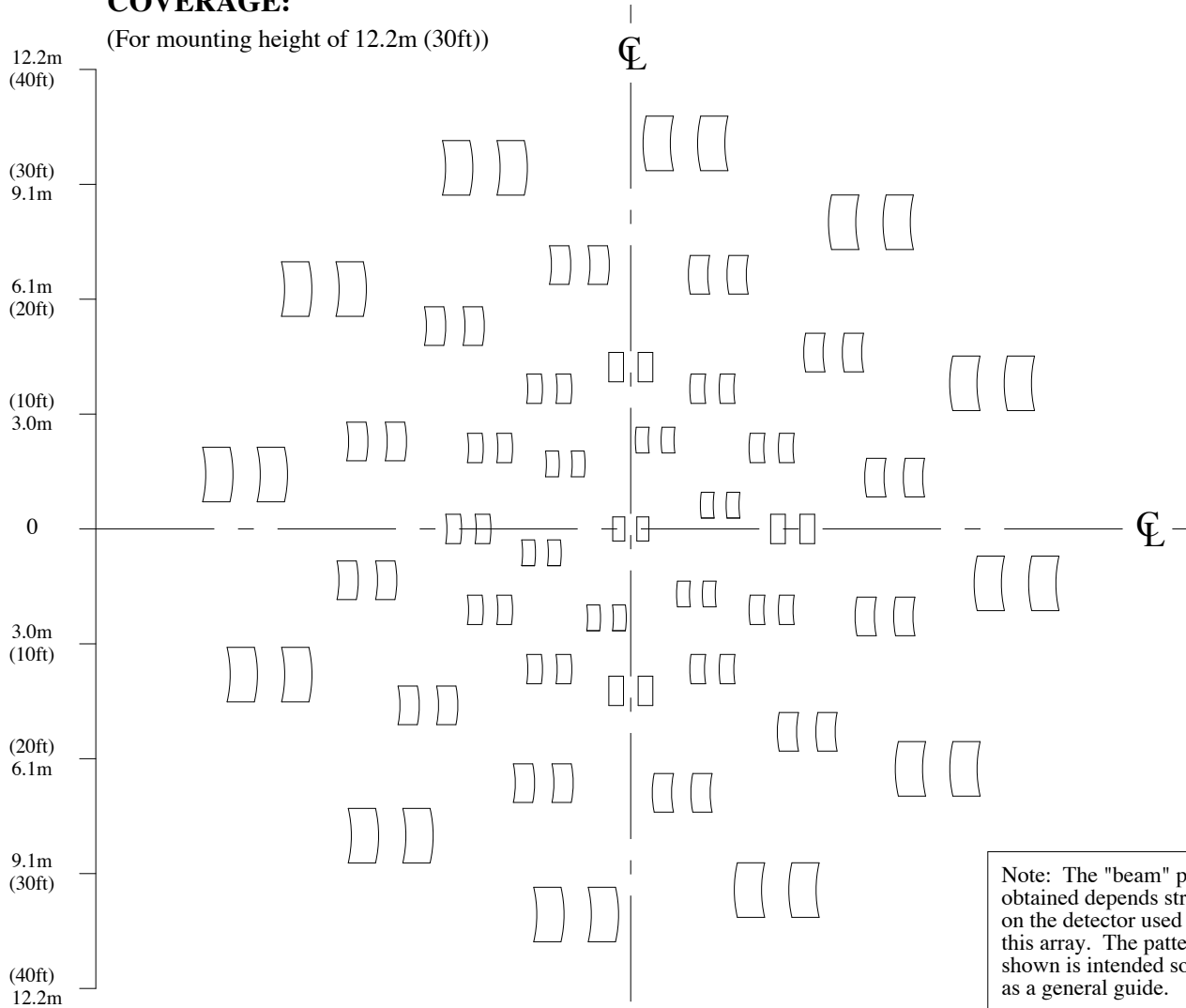

Figure 10

CEILING MOUNT ARRAY CM 0.77 GI V5

FLOOR COVERAGE:

(For mounting height of 12.2m (30ft))



Note: The "beam" pattern obtained depends strongly on the detector used with this array. The pattern shown is intended solely as a general guide.

SIDE VIEW:

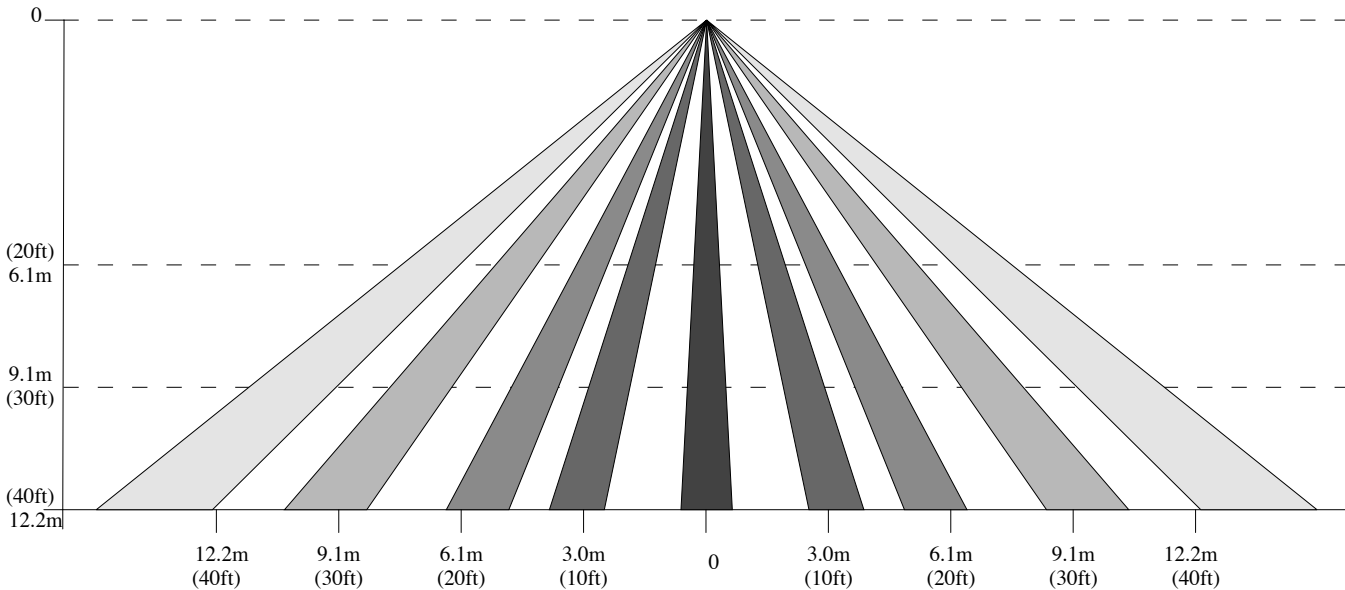

fresnel technologies inc.
© 2008

101W. MORNINGSDR. FORT WORTH, TX 76110, U. S. A. (817) 926-7474, FAX:(817) 926-7146

Figure 11

CEILING MOUNT ARRAY CM 0.77 GI V5

FLOOR COVERAGE:

(For mounting height of 12.2m (30ft),
and when a 4 element is used)



Note: The "beam" pattern obtained depends strongly on the detector used with this array. The pattern shown is intended solely as a general guide.

SIDE VIEW:

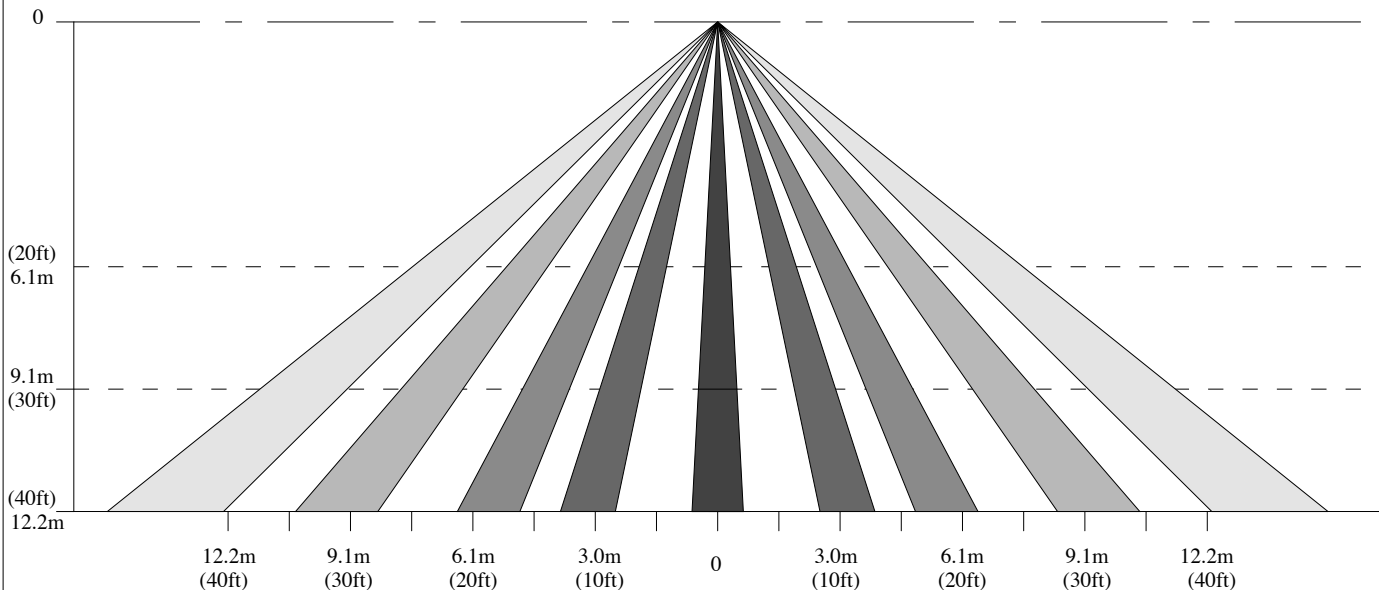

Figure 12